

Floor Elements  
地面组件

Mounting Plate  
支脚连接板

To attach leveling foot to strut profile end, however it does not apply for connecting of castors.

连接支脚与型材端面, 不适用于脚轮的连接。

Material: diecast aluminum

材质: 压铸铝合金

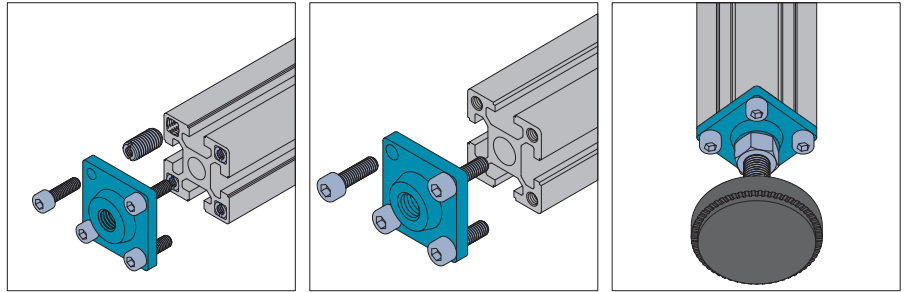



PG40-40x40  
PG45-45x45  
PG50-50x50

PG40-40x60  
PG45-45x60

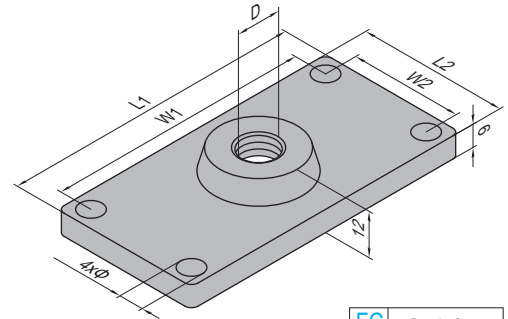
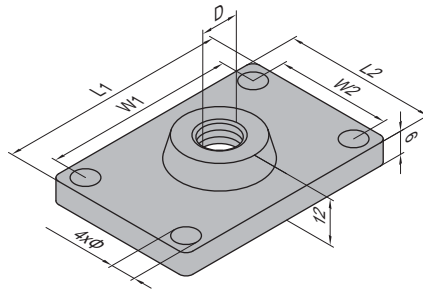
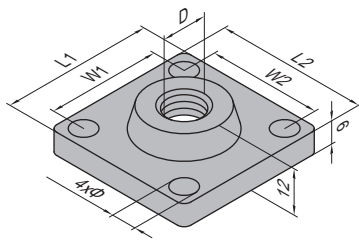
PG40-40x80  
PG45-45x90



FC	Fastening Set
	M6x20 Bolt zinc plated
	M10-M6 Hole Reducer Bolt nickel plated

Description 产品描述	D	Φ	L1 (mm)	L2 (mm)	W1 (mm)	W2 (mm)	Fastening Set 紧固组件	Mass 重量 (g)	Part No. 订购编号
Mounting Plate-PG40-4040 支脚连接板-40系列-4040	M12	6.5	40	40	30	30	4x(M6x20)	51	5.31.40.4040
Mounting Plate-PG45-4545 支脚连接板-45系列-4545	M12		45	45	33	33	4xFC	97	5.31.45.4545
Mounting Plate-PG50-5050 支脚连接板-50系列-5050	M12	8.5	50	50	35	35	4x(M8x30)	130	5.31.50.5050
Mounting Plate-PG40-4060 支脚连接板-40系列-4060	M12	6.5	60	40	50	30	4x(M6x20)	67	5.31.40.4060
Mounting Plate-PG45-4560 支脚连接板-45系列-4560	M12		60	45	48	33	4xFC	108	5.31.45.4560
Mounting Plate-PG40-4080 支脚连接板-40系列-4080	M12		80	40	70	30	4x(M6x20)	78	5.31.40.4080.M12
	M16						4x(M6x20)	78	5.31.40.4080.M16
Mounting Plate-PG45-4590 支脚连接板-45系列-4590	M12		90	45	78	33	4xFC	131	5.31.45.4590.M12
	M16					4xFC	128	5.31.45.4590.M16	

Note: offer per set (including fastening set).

备注: 成套供货 (包含紧固组件)。