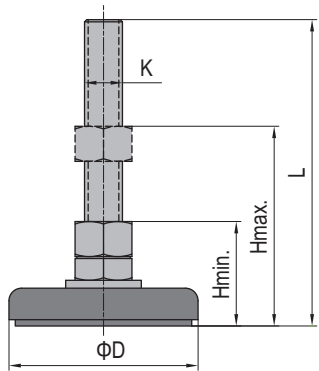

Floor Elements
 地面组件

 Leveling Foot-Fixed Foot
 支脚-固定

Fixed foot have a non-moving connection between base and spindle.
 固定支脚的牙杆和底盘间是不可活动的。

Material and Color: Base Plate-steel, electrophoresis, black Spindle-zinc plated steel Pad-black rubber
 材质: 底盘-碳钢电泳 牙杆-碳钢镀锌 胶垫-橡胶 颜色: 底盘-黑色 胶垫-黑色

 Fixed Foot
 固定支脚

Description 产品描述	D (mm)	KxL (mm)	H min. (mm)	H max. (mm)	Max. Static Load 最大静态载荷 (N)	Mass 重量 (g)	Part No. 订购编号
Fixed Foot-Steel Base 固定支脚-碳钢底盘	40	M12x70	35	50	4000	124	5.23.40.12.70
	60	M12x70	35	50	7000	181	5.23.60.12.70
		M14x70	38	50		225	5.23.60.14.70
	80	M12x70	35	50	9000	220	5.23.80.12.70
		M12x110	35	80		240	5.23.80.12.110
		M14x70	38	50		283	5.23.80.14.70

Ad:M14 Fixed Foot should use an end cap with a punched hole
 注: 固定支脚M14使用打孔端盖

 Leveling Foot-Pivot Foot
 支脚-金属微调

To support structure where gradual height adjustment is needed, the pivot foot has a small swiveling angle to fit slightly uneven floor. The connection between the pivot base and the spindle can be released with a tool.

金属微调支脚用来支撑需要调整高度的框架结构, 调节角度较小, 适用于相对平整的地面, 此支脚的牙杆和底盘可用工具拆分。

Material: zinc plated steel/stainless steel
 材质: 碳钢镀锌/不锈钢

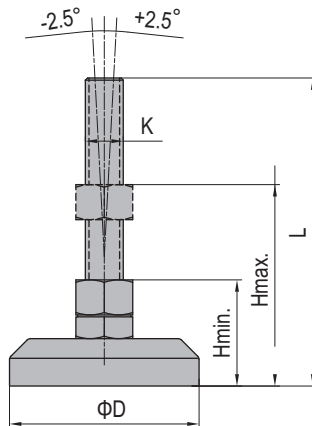
 Pivot Foot
 金属微调支脚

Description 产品描述	D (mm)	KxL (mm)	H min. (mm)	H max. (mm)	Max. Static Load 最大静态载荷 (N)	Mass 重量 (g)	Part No. 订购编号	
Pivot Foot-Zinc Plate Steel 金属微调支脚-碳钢镀锌	40	M12x128	45	100	15000	241	5.24.40.12.130	
		M14x128	45	100	17000	290	5.24.40.14.130 New!	
	60	M12x128	45	100	15000	475	5.24.60.12.130	
		M14x128	45	100	17000	523	5.24.60.14.130	
		M16x158	45	120	20000	596	5.24.60.16.160	
		M20x178	50	130	25000	796	5.24.60.20.180	
	80	M12x128	45	100	15000	670	5.24.80.12.130	
		M16x158	45	120	20000	780	5.24.80.16.160	
		M20x178	50	130	25000	945	5.24.80.20.180	
	Pivot Foot-Stainless Steel 金属微调支脚-不锈钢	40	M12x128	45	100	15000	240	5.24.40.12.130.SS
			M12x128	45	100	15000	480	5.24.60.12.130.SS
		60	M16x158	45	120	20000	600	5.24.60.16.160.SS
M20x178			50	130	25000	803	5.24.60.20.180.SS	
M12x128			45	100	15000	675	5.24.80.12.130.SS	
80		M16x158	45	120	20000	785	5.24.80.16.160.SS	
		M20x178	50	130	25000	950	5.24.80.20.180.SS	

