

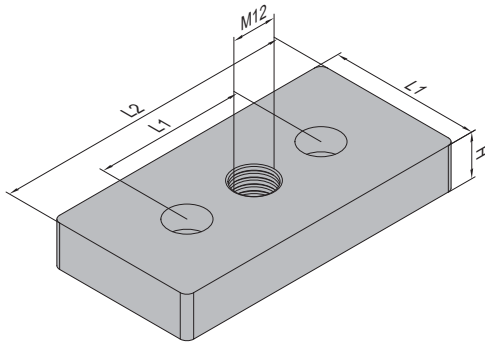

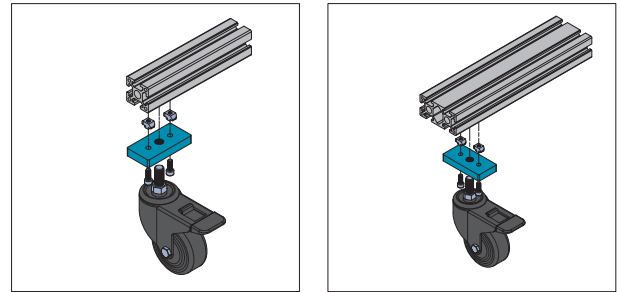

Floor Elements
 地面组件

 Castor Plate New!
 脚轮连接板

The castor plate used for attaching profil to the castor with thread.
 此脚轮连接板用于型材平面与牙杆式脚轮的连接。

Material: zinc plated steel
 材质: 碳钢镀锌



FS	Fastening Set	CQ	Fastening Set
	M6x10 Bolt zinc plated		M6x16 Bolt zinc plated
	M6 T Nut nickel plated		M6 T Nut nickel plated

Description 产品描述	H (mm)	L1 (mm)	L2 (mm)	Fastening Set 紧固组件	Mass 重量 (g)	Part No. 订购编号
Castor Plate-PG30 -(set) 脚轮连接板-30系列-(成套供货)	10	30	60	2xCP	162	5.35.30.ST
Castor Plate-PG40 -(set) 脚轮连接板-40系列-(成套供货)	12	40	80	2xCQ	296	5.35.40.ST
Castor Plate-PG45 -(set) 脚轮连接板-45系列-(成套供货)	12	45	90	2xCQ	377	5.35.45.ST

Note: offer per set (including fastening set).

备注: 成套供货 (含紧固件)。

When a castor is installed as figure indicated, the profile end corresponding to the position of the castor lever requires machining of a $\Phi 12.5$ and 20mm deep hole.

使用此方式安装脚轮时, 型材对应脚轮牙杆的位置需要加工1个 $\Phi 12.5$ 深20mm的孔。