

Floor Elements  
地面组件

Foot and Castor Components  
支脚万向轮组件

Material and Color: steel silver  
板材材质和颜色: 铸钢 银色

Light Load Wheel-polyurethane Foot-steel, black electrophoresis  
轻载 轮-聚氨酯 支脚-碳钢电泳

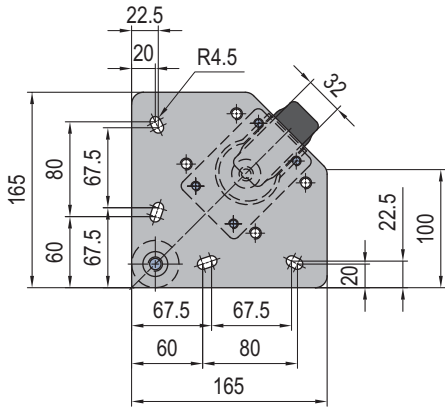
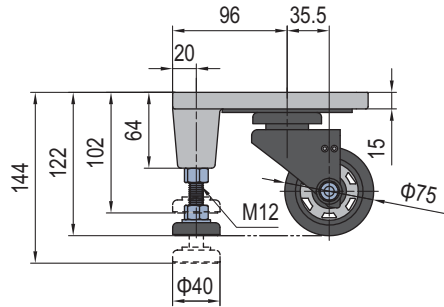

Heavy Load Wheel-Nylon Foot-carbon steel zinc plated  
重载 轮-尼龙 支脚-碳钢镀锌

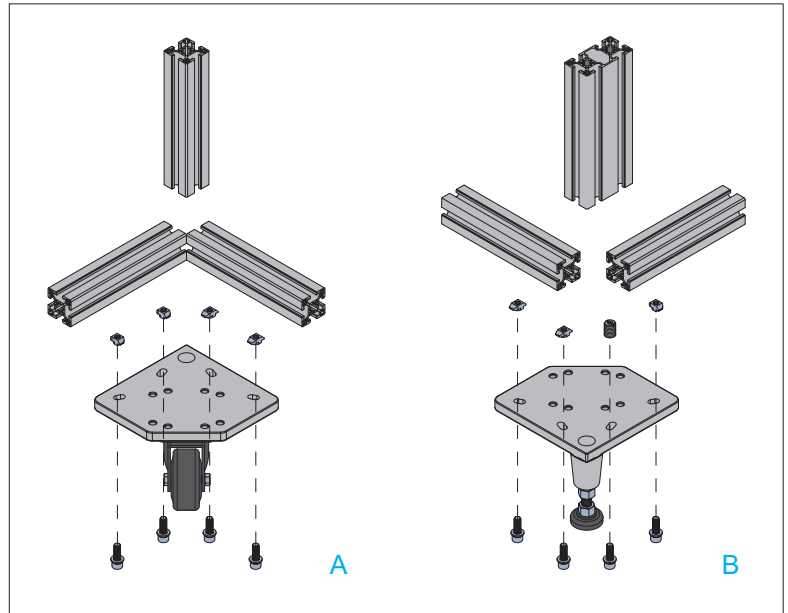
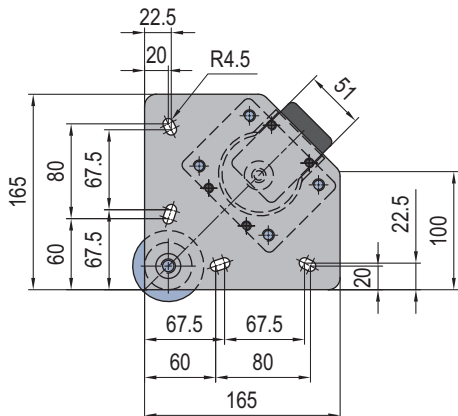
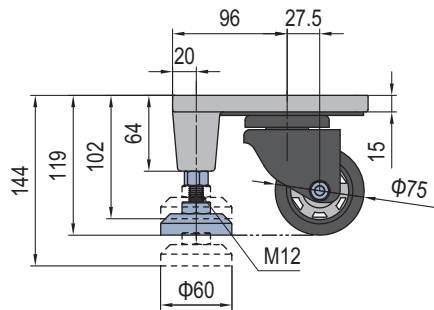

AF	Fastening Set	AG	Fastening Set	J	Fastening Set	W	Fastening Set
	M8x25 Bolt zinc plated		M8x30 Bolt zinc plated		M8x25 Bolt zinc plated		M8x30 Bolt zinc plated
	M8 Spring Washer zinc plated		M8 Spring Washer zinc plated		M8 Spring Washer zinc plated		M8 Spring Washer zinc plated
	M8 Washer zinc plated		M8 Washer zinc plated		M8 Washer zinc plated		M8 Washer zinc plated
	M14-M8 Hole Reducer Bolt nickel plated		M14-M8 Hole Reducer Bolt nickel plated		M8 T Nut zinc plated		M8 T Nut nickel plated

Description 产品描述	Fastening Set 紧固组件	Load 载荷 (N)	Mass 重量 (g)	Part No. 订购编号
支脚万向轮组件 轻载 Light Weight		1050	3900	5.61.L
	4xJ	1050	3950	5.61.40.L.STA
	3xJ+1xAF	1050	3950	5.61.40.L.STB
	4xW	1050	3950	5.61.45.L.STA
支脚万向轮组件 重载 Heavy Weight		6000	4600	5.61.H
	4xJ	6000	4650	5.61.40.H.STA
	3xJ+1xAF	6000	4650	5.61.40.H.STB
	4xW	6000	4650	5.61.45.H.STA
	3xW+1xAG	6000	4650	5.61.45.H.STB