

Panel Installation Elements
板材组件

Panel Mounting Block
板夹块

The block can be used to attach the profile and panel of various thickness.
板夹块用于板材与型材的连接，不同的夹面适合不同厚度的板材。
Material and Color: Block-black PC Nut-stainless steel
材质和颜色：夹块-PC 黑色 螺母-不锈钢

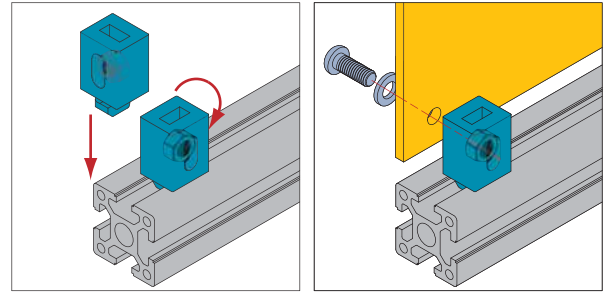

Panel Mounting Block-6
板夹块-6

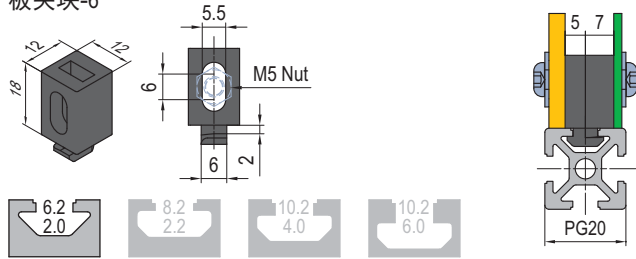

FM	Fastening Set	FN	Fastening Set	FP	Fastening Set
	M5x14 Bolt zinc plated		M6x16 Bolt zinc plated		M6x25 Bolt zinc plated
	M5 Washer zinc plated		M6 Washer zinc plated		M6 Washer zinc plated

Panel Mounting Block-8
板夹块-8

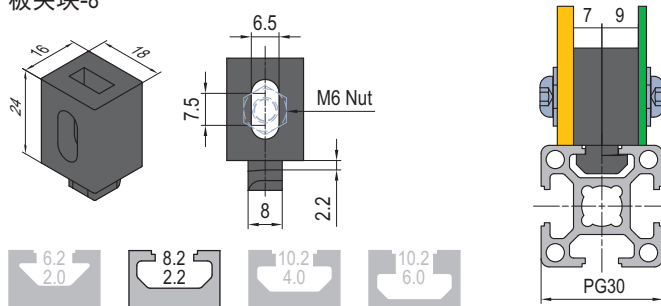

Description 产品描述	Fastening Set 紧固组件	Mass 重量 (g)	Part No. 订购编号
Panel Mounting Block-6 (pcs) 板夹块-6 (单个供货)		4.4	6.21.06
Panel Mounting Block-6 (set) 板夹块-6 (成套供货)	1xFM	7	6.21.06.ST
Panel Mounting Block-8 (pcs) 板夹块-8 (单个供货)		9	6.21.08
Panel Mounting Block-8 (set) 板夹块-8 (成套供货)	1xFN	13.5	6.21.08.ST
Panel Mounting Block-10-4 (pcs) 板夹块-10-4 (单个供货)		15.8	6.21.10.04
Panel Mounting Block-10-4 (set) 板夹块-10-4 (成套供货)	1xFP	23.8	6.21.10.04.ST
Panel Mounting Block-10-6 (pcs) 板夹块-10-6 (单个供货)		20	6.21.10.06
Panel Mounting Block-10-6 (set) 板夹块-10-6 (成套供货)	1xFP	29	6.21.10.06.ST

Panel Mounting Block-10-4
板夹块-10-4

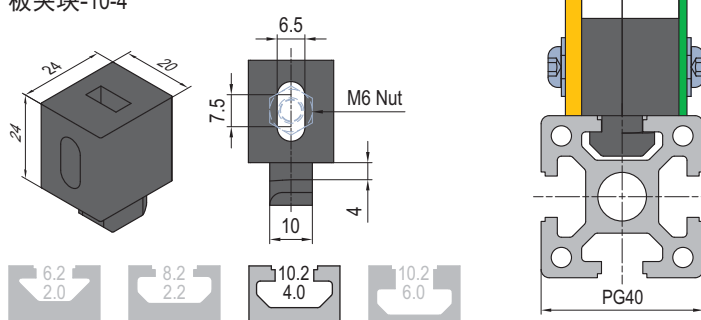

Panel Mounting Block-10-6
板夹块-10-6

