

Additional Accessories
其他附件

Joint
枢轴
To attach electrical box or connect movable profiles.
枢轴用来连接可活动的型材。
Material: zinc plated steel
材质: 碳钢镀锌

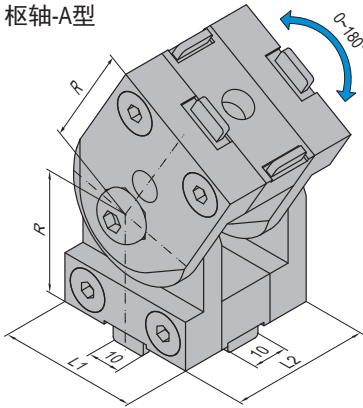

Joint-Type A
枢轴-A型



Joint-Type B
枢轴-B型

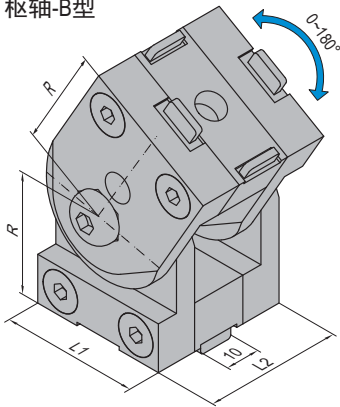

Joint-Type C
枢轴-C型

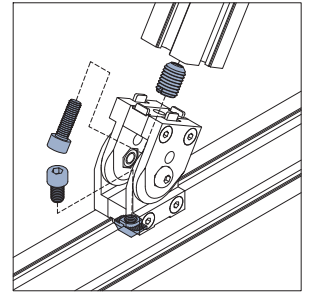
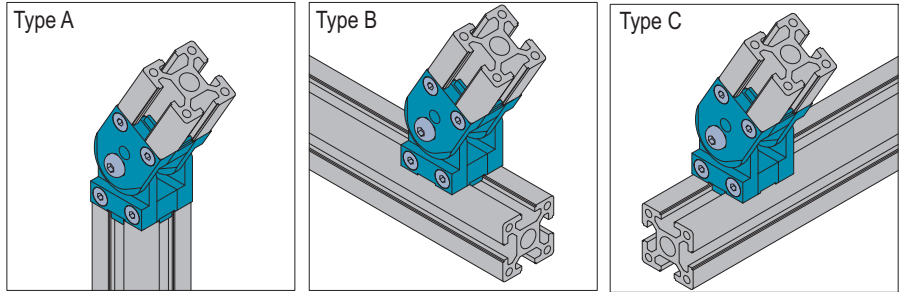
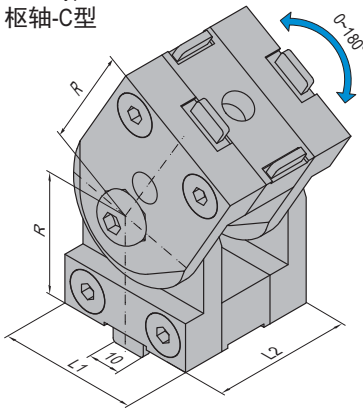

FD	Fastening Set	FX	Fastening Set
	M8x16 Bolt zinc plated		M8x20 Bolt zinc plated
	M8 T Nut nickel plated		M14-M8 Hole Reducer Bolt nickel plated

Description 描述	L1 (mm)	L2 (mm)	R (mm)	Fastening Set 紧固组件	Mass 重量 (g)	Part No. 订购编号
Joint-Type A-4040 枢轴-A型-4040	40	40	35	2xFX	560	8.31.4040A
Joint-Type A-4060 枢轴-A型-4060	40	60	35	2xFX	680	8.31.4060A
Joint-Type A-4545 枢轴-A型-4545	45	45	37.5	2xFX	650	8.31.4545A
Joint-Type A-4560 枢轴-A型-4560	45	60	37.5	2xFX	800	8.31.4560A
Joint-Type B-4040 枢轴-B型-4040	40	40	35	1xFD+1xFX	575	8.31.4040B
Joint-Type B-4060 枢轴-B型-4060	40	60	35	1xFD+1xFX	695	8.31.4060B
Joint-Type B-4545 枢轴-B型-4545	45	45	37.5	1xFD+1xFX	665	8.31.4545B
Joint-Type B-4560 枢轴-B型-4560	45	60	37.5	1xFD+1xFX	815	8.31.4560B
Joint-Type C-4040 枢轴-C型-4040	40	40	35	1xFD+1xFX	575	8.31.4040C
Joint-Type C-4060 枢轴-C型-4060	40	60	35	1xFD+1xFX	695	8.31.4060C
Joint-Type C-4545 枢轴-C型-4545	45	45	37.5	1xFD+1xFX	665	8.31.4545C
Joint-Type C-4560 枢轴-C型-4560	45	60	37.5	1xFD+1xFX	815	8.31.4560C

Note: offer per set (including fastening set).
备注: 成套供货(包含紧固组件)。