

Additional Accessories  
其他附件

Joint **New!**  
枢轴

To attach electrical box or connect movable profiles.  
枢轴用来连接可活动的型材。

Material: zinc alloy  
材质：锌合金

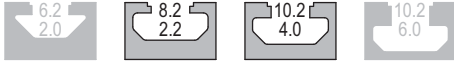

Joint-Type A  
枢轴-A型

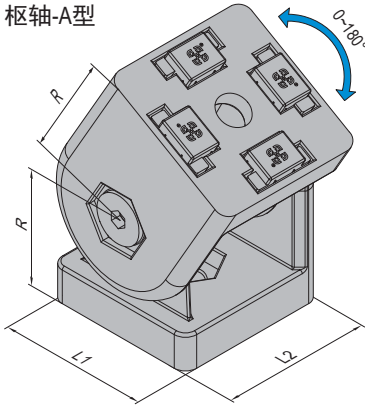



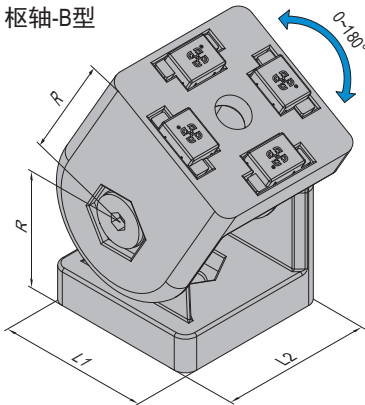



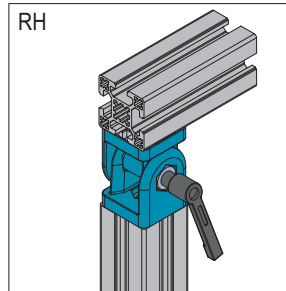
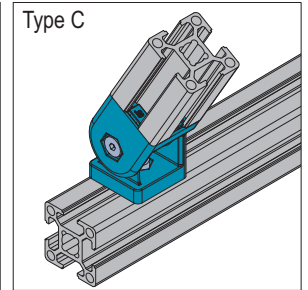
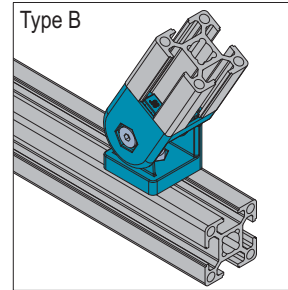
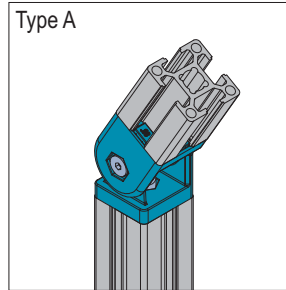
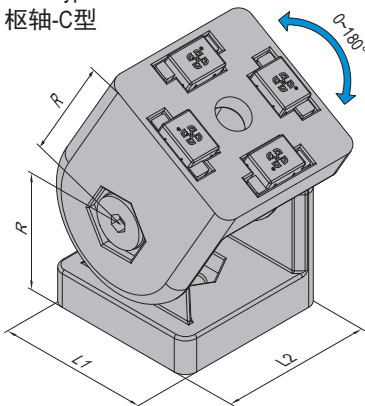

Joint-Type B  
枢轴-B型



Joint-Type C  
枢轴-C型



Note: Ratchet handle (part number RH) is an optional accessory for all three ways of connections of type A, B and C.  
备注：此枢轴三种连接方式A、B和C都可配棘轮把手，编号RH。

FS	Fastening Set	FO	Fastening Set	FU	Fastening Set	FX	Fastening Set
	M6x10 Bolt zinc plated		M6x16 Bolt zinc plated		M8x12 Bolt zinc plated		M8x20 Bolt zinc plated
	M6 T Nut nickel plated		M12-M6 Hole Reducer Bolt nickel plated		M8 T Nut nickel plated		M14-M8 Hole Reducer Bolt nickel plated

Description 描述	L1 (mm)	L2 (mm)	R (mm)	Fastening Set 紧固组件	Mass 重量 (g)	Part No. 订购编号
Joint-Type A-3030 枢轴-A型-3030	30	30	22.5	2xFO	181	8.32.3030A
Joint-Type A-3030-RH 枢轴-A型-3030-RH	30	30	22.5	2xFO	181	8.32.3030A.RH
Joint-Type A-4040 枢轴-A型-4040	40	40	30	2xFX	388	8.32.4040A
Joint-Type A-4040-RH 枢轴-A型-4040-RH	40	40	30	2xFX	388	8.32.4040A.RH
Joint-Type B-3030 枢轴-B型-3030	30	30	22.5	1xFS+1xFO	167	8.32.3030B
Joint-Type B-3030-RH 枢轴-B型-3030-RH	30	30	22.5	1xFS+1xFO	167	8.32.3030B.RH
Joint-Type B-4040 枢轴-B型-4040	40	40	30	1xFU+1xFX	366	8.32.4040B
Joint-Type B-4040-RH 枢轴-B型-4040-RH	40	40	30	1xFU+1xFX	366	8.32.4040B.RH
Joint-Type C-3030 枢轴-C型-3030	30	30	22.5	1xFS+1xFO	167	8.32.3030C
Joint-Type C-3030-RH 枢轴-C型-3030-RH	30	30	22.5	1xFS+1xFO	167	8.32.3030C.RH
Joint-Type C-4040 枢轴-C型-4040	40	40	30	1xFU+1xFX	366	8.32.4040C
Joint-Type C-4040-RH 枢轴-C型-4040-RH	40	40	30	1xFU+1xFX	366	8.32.4040C.RH

Note: offer per set (including fastening set).  
备注：成套供货(包含紧固组件)。