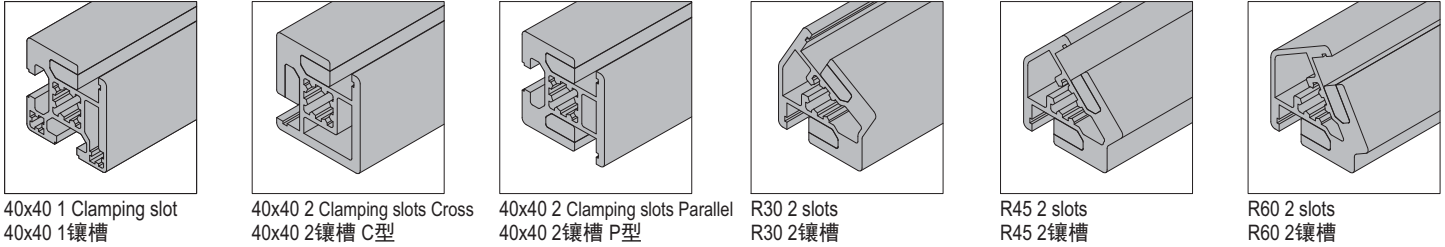
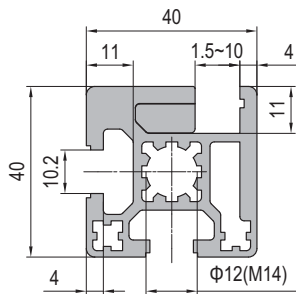
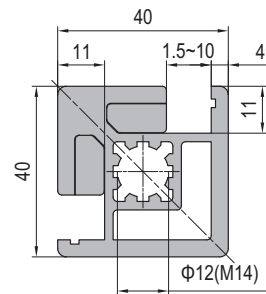
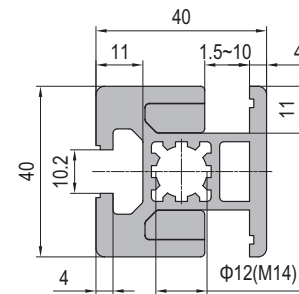
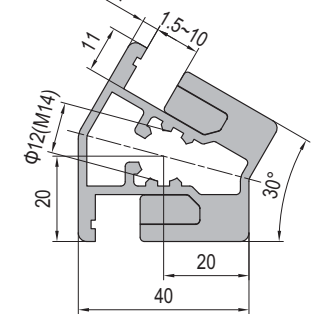
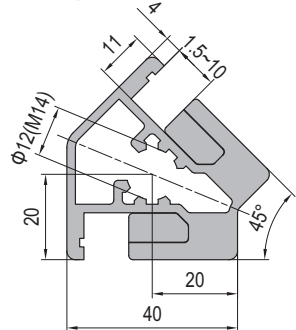
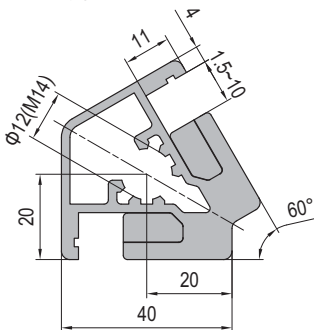

Clamping Profile PG40
防护罩型材 40系列

Clamping Profiles only could insert the panels, and machining will be needed on the with thickness range of 1.5-10mm. profiles to fasten the panels in appropriate positions, the recommended distance of machining is 300mm.

防护罩型材只能用于板状物的安装，板厚度范围为1.5-10mm，安装时需要在型材上加工顶丝孔，建议顶丝安装间距为300mm。

 40x40 1 Clamping slot
40x40 1 镶槽

 40x40 2 Clamping slots Cross
40x40 2 镶槽 C型

 40x40 2 Clamping slots Parallel
40x40 2 镶槽 P型

 R30 2 slots
R30 2 镶槽

 R45 2 slots
R45 2 镶槽

 R60 2 slots
R60 2 镶槽

Connector selection
推荐连接件

Machine Guard System
机械防护系统样册



-  Bushing
连接套-40 PPJ40.ST
-  Hole Reducer Bolt
变径螺栓 2.51.14.08
-  End Cap for clamping profile
改制防护罩端盖 4.12.40.4040SM

Description 产品描述	Moment of Inertia 惯性矩 Ix(cm ⁴)	Moment of Inertia 惯性矩 Iy(cm ⁴)	Moment of Resistance 弯矩 Wx(cm ³)	Moment of Resistance 弯矩 Wy(cm ³)	Mass 重量 (kg/m)	Part No. 订购编号
Clamping Profile PG40 40x40 1 Clamping slot 防护罩型材 40系列 40x40 1 镶槽	12.3	9.5	4.4	3.4	2.2	1.21.40.040040.01
Clamping Profile PG40 40x40 2 Clamping slots Cross 防护罩型材 40系列 40x40 2 镶槽 C型	14.7	10.0	5.2	3.7	2.6	1.21.40.040040.02C
Clamping Profile PG40 40x40 2 Clamping slots Parallel 防护罩型材 40系列 40x40 2 镶槽 P型	12.4	12.1	5.8	6.1	2.6	1.21.40.040040.02P
Clamping Profile PG40 R30 2 Clamping slots 防护罩型材 40系列 R30 2 镶槽	12.2	10.6	4.9	4.4	2.5	1.21.40.040040.R30
Clamping Profile PG40 R45 2 Clamping slots 防护罩型材 40系列 R45 2 镶槽	12.3	10.0	4.7	3.9	2.5	1.21.40.040040.R45
Clamping Profile PG40 R60 2 Clamping slots 防护罩型材 40系列 R60 2 镶槽	12.2	9.5	4.4	3.6	2.5	1.21.40.040040.R60