

Connecting Elements
连接件

Anchor Connector
锚式连接销

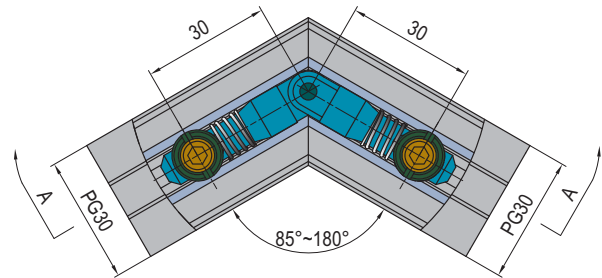

PG30-Miter (Model P)
30系列-对接型 (P)

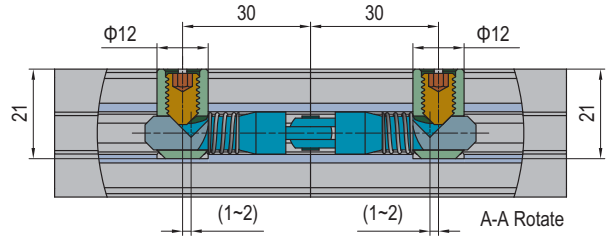
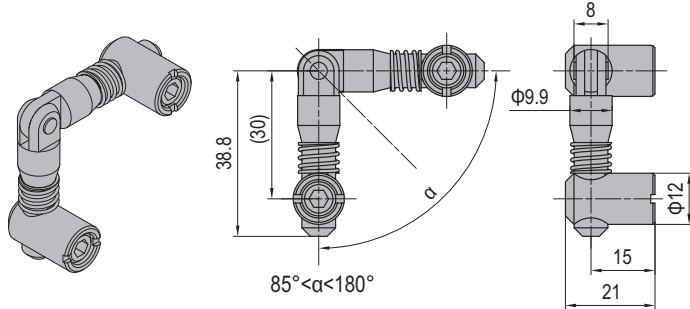

PG30-Miter (Model C)
30系列-对接型 (C)

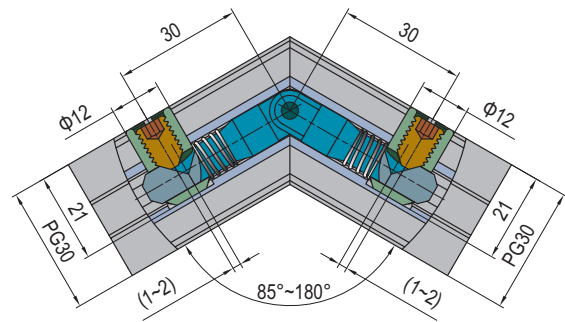
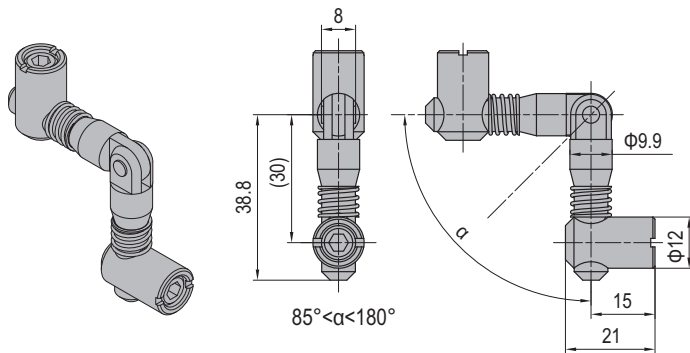

| Description 产品描述 | Material 材质 | Mass 重量 (g/unit) | Part No. 订购编号 |
|---|---------------------------|------------------------|------------------|
| Anchor Connector-PG30-Miter (Model P) 锚式连接销-30系列-对接型 (P) | zinc plated steel 碳钢镀锌 | 63 | 3.11.30.06 |
| Anchor Connector-PG30-Miter (Model C) 锚式连接销-30系列-对接型 (C) | zinc plated steel 碳钢镀锌 | 63 | 3.11.30.07 |