

Connecting Elements
连接件

Die Cast Bracket
压铸角铝
Material: diecast aluminum
材质: 压铸铝合金

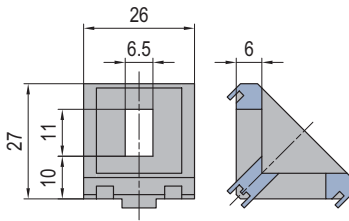

PG30-30x30
30系列-30x30



PG30-30x60
30系列-30x60

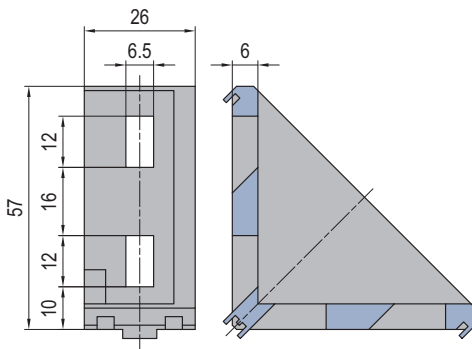

PG30-60x60
30系列-60x60

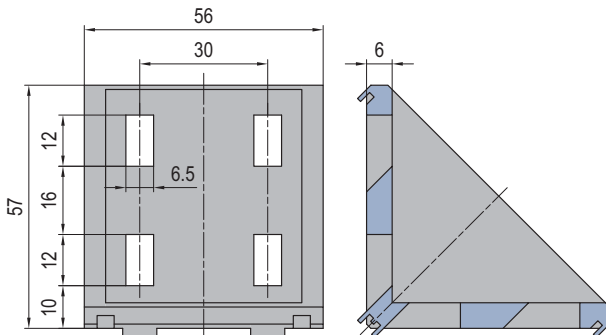

A	Fastening Set	B	Fastening Set
	M6x14 Bolt zinc plated		M6x14 Bolt zinc plated
	M6 Washer zinc plated		M6 Washer zinc plated
	M6 T Nut nickel plated		M6 Pre-set Nut nickel plated

Description 产品描述	Fastening Set 紧固组件	Mass 重量 (g)	Part No. 订购编号
PG30-30x30 (pcs) 30系列-30x30 (单个供货)		21	3.21.30.3030
PG30-30x30 (set A) 30系列-30x30 (成套供货A)	2xA	42	3.21.30.3030.STA
PG30-30x30 (set B) 30系列-30x30 (成套供货B)	2xB	48	3.21.30.3030.STB
PG30-30x60 (pcs) 30系列-30x60 (单个供货)		53	3.21.30.3060
PG30-30x60 (set A) 30系列-30x60 (成套供货A)	4xA	93	3.21.30.3060.STA
PG30-30x60 (set B) 30系列-30x60 (成套供货B)	4xB	105	3.21.30.3060.STB
PG30-60x60 (pcs) 30系列-60x60 (单个供货)		120	3.21.30.6060
PG30-60x60 (set A) 30系列-60x60 (成套供货A)	8xA	200	3.21.30.6060.STA
PG30-60x60 (set B) 30系列-60x60 (成套供货B)	8xB	224	3.21.30.6060.STB