

Connecting Elements
连接件

Angle Profile Bracket
挤压角铝

Material: aluminium, anodized (cutting end not anodized)
材质: 铝合金, 表面阳极氧化 (切面无处理)



50x50x9

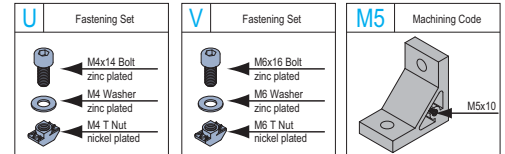
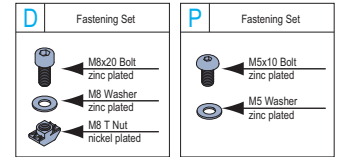
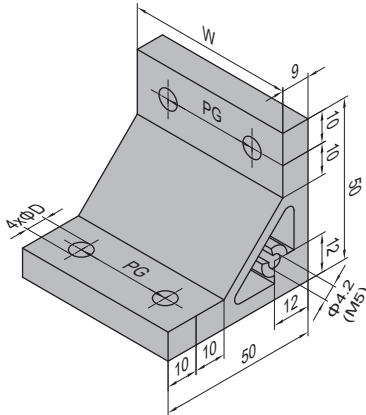

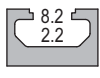
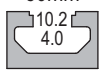
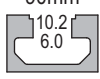
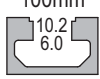
Application 应用	Description 产品描述	D (mm)	W (mm)	PG (mm)	Fastening Set 紧固组件	Machining Code 加工代码	Mass 重量 (g)	Part No. 订购编号
PG20 40mm 	50-20-40 (pcs/单个供货)	4.5	34	20			75	3.31.50.20.40
	50-20-40 (set/成套供货)	4.5	34	20	4xU		95	3.31.50.20.40.ST
	50-20-40 (M5/加工供货)	4.5	34	20		M5	75	3.31.50.20.40.M5
	50-20-40 (M5 set/成套加工供货)	4.5	34	20	4xU+1xP	M5	97	3.31.50.20.40.M5.ST
PG30 60mm 	50-30-60 (pcs/单个供货)	6.5	52	30			114	3.31.50.30.60
	50-30-60 (set/成套供货)	6.5	52	30	4xV		156	3.31.50.30.60.ST
	50-30-60 (M5/加工供货)	6.5	52	30		M5	114	3.31.50.30.60.M5
	50-30-60 (M5 set/成套加工供货)	6.5	52	30	4xV+1xP	M5	158	3.31.50.30.60.M5.ST
PG40 80mm 	50-40-80 (pcs/单个供货)	8.5	70	40			154	3.31.50.40.80
	50-40-80 (set/成套供货)	8.5	70	40	4xD		240	3.31.50.40.80.ST
	50-40-80 (M5/加工供货)	8.5	70	40		M5	154	3.31.50.40.80.M5
	50-40-80 (M5 set/成套加工供货)	8.5	70	40	4xD+1xP	M5	242	3.31.50.40.80.M5.ST
PG45 90mm 	50-45-90 (pcs/单个供货)	8.5	80	45			176	3.31.50.45.90
	50-45-90 (set/成套供货)	8.5	80	45	4xD		262	3.31.50.45.90.ST
	50-45-90 (M5/加工供货)	8.5	80	45		M5	176	3.31.50.45.90.M5
	50-45-90 (M5 set/成套加工供货)	8.5	80	45	4xD+1xP	M5	264	3.31.50.45.90.M5.ST
PG50 100mm 	50-50-100 (pcs/单个供货)	8.5	90	50			198	3.31.50.50.100
	50-50-100 (set/成套供货)	8.5	90	50	4xD		284	3.31.50.50.100.ST
	50-50-100 (M5/加工供货)	8.5	90	50		M5	198	3.31.50.50.100.M5
	50-50-100 (M5 set/成套加工供货)	8.5	90	50	4xD+1xP	M5	286	3.31.50.50.100.M5.ST