

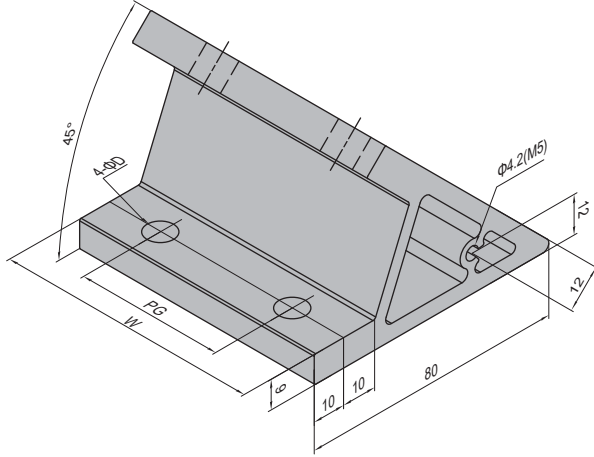









Connecting Elements
 连接件

 Angle Profile Bracket
 挤压角铝

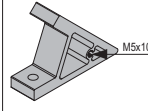
 Material: aluminium, anodized (cutting end not anodized)
 材质: 铝合金, 表面阳极氧化 (切面无处理)

80x80x9-45°

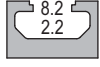
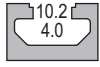
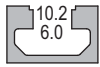
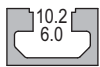

D	Fastening Set	P	Fastening Set	V	Fastening Set	M5	Machining Code
	M8x20 Bolt zinc plated		M5x10 Bolt zinc plated		M6x18 Bolt zinc plated		M5x10
	M8 Washer zinc plated		M5 Washer zinc plated		M6 Washer zinc plated		
	M8 T Nut nickel plated				M6 T Nut nickel plated		

Application 应用	Description 产品描述	D (mm)	W (mm)	PG (mm)	Fastening Set 紧固组件	Machining Code 加工代码	Mass 重量 (g)	Part No. 订购编号
PG30 60mm 	80-30-60 (pcs/单个供货)	7	52	30			156	3.31.80.30.60
	80-30-60 (set/成套供货)	7	52	30	4xV		198	3.31.80.30.60.ST
	80-30-60 (M5/加工供货)	7	52	30		M5	156	3.31.80.30.60.M5
	80-30-60 (M5 set/成套加工供货)	7	52	30	4xV+1xP	M5	200	3.31.80.30.60.M5.ST
PG40 80mm 	80-40-80 (pcs/单个供货)	9	70	40			209	3.31.80.40.80
	80-40-80 (set/成套供货)	9	70	40	4xD		295	3.31.80.40.80.ST
	80-40-80 (M5/加工供货)	9	70	40		M5	209	3.31.80.40.80.M5
	80-40-80 (M5 set/成套加工供货)	9	70	40	4xD+1xP	M5	297	3.31.80.40.80.M5.ST
PG45 90mm 	80-45-90 (pcs/单个供货)	9	80	45			240	3.31.80.45.90
	80-45-90 (set/成套供货)	9	80	45	4xD		326	3.31.80.45.90.ST
	80-45-90 (M5/加工供货)	9	80	45		M5	240	3.31.80.45.90.M5
	80-45-90 (M5 set/成套加工供货)	9	80	45	4xD+1xP	M5	328	3.31.80.45.90.M5.ST
PG50 100mm 	80-50-100 (pcs/单个供货)	9	90	50			271	3.31.80.50.100
	80-50-100 (set/成套供货)	9	90	50	4xD		357	3.31.80.50.100.ST
	80-50-100 (M5/加工供货)	9	90	50		M5	271	3.31.80.50.100.M5
	80-50-100 (M5 set/成套加工供货)	9	90	50	4xD+1xP	M5	359	3.31.80.50.100.M5.ST