

Connecting Elements
连接件

Joining Plate **New!**

连接板

Material: zinc plated steel

材质: 碳钢镀锌

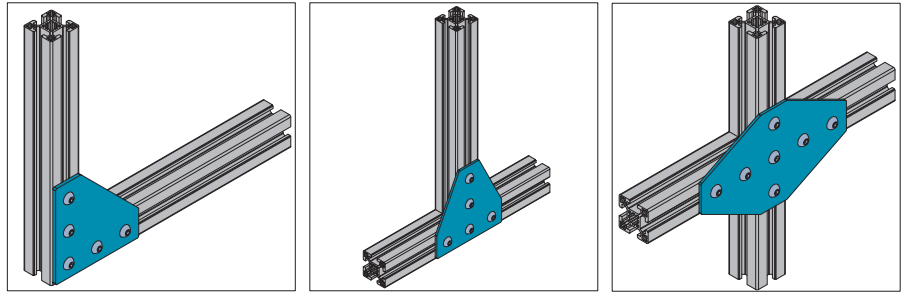

PG40-4040-04
40系列-4040-04

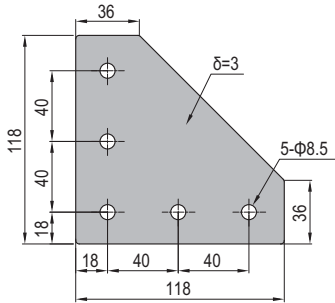

X	Fastening Set	Y	Fastening Set
	M8x12 Bolt zinc plated		M8x12 Bolt zinc plated
	M8 Washer zinc plated		M8 Washer zinc plated
	M8 T Nut nickel plated		M8 Pre-set Nut nickel plated

PG40-4040-05
40系列-4040-05

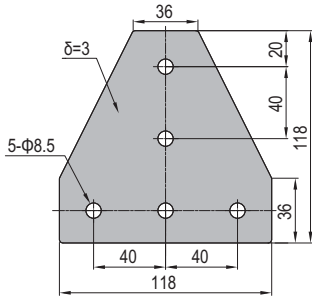

PG40-4040-06
40系列-4040-06

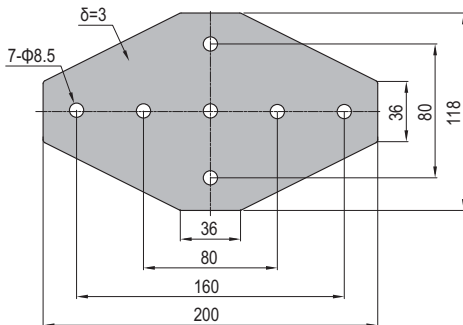

Description 产品描述	Fastening Set 紧固组件	Mass 重量 (g)	Part No. 订购编号
PG40-4040-04 (pcs) 40系列-4040-04 (单个供货)		324	3.53.40.4040.04
PG40-4040-04 (set X) 40系列-4040-04 (成套供货X)	5xX	409	3.53.40.4040.04.STX
PG40-4040-04 (set Y) 40系列-4040-04 (成套供货Y)	5xY	454	3.53.40.4040.04.STY
PG40-4040-05 (pcs) 40系列-4040-05 (单个供货)		324	3.53.40.4040.05
PG40-4040-05 (set X) 40系列-4040-05 (成套供货X)	5xX	409	3.53.40.4040.05.STX
PG40-4040-05 (set Y) 40系列-4040-05 (成套供货Y)	5xY	454	3.53.40.4040.05.STY
PG40-4040-06 (pcs) 40系列-4040-06 (单个供货)		518	3.53.40.4040.06
PG40-4040-06 (set X) 40系列-4040-06 (成套供货X)	7xX	637	3.53.40.4040.06.STX
PG40-4040-06 (set Y) 40系列-4040-06 (成套供货Y)	7xY	700	3.53.40.4040.06.STY