

Connecting Elements
连接件

Joining Plate **New!**

连接板

Material: zinc plated steel

材质: 碳钢镀锌

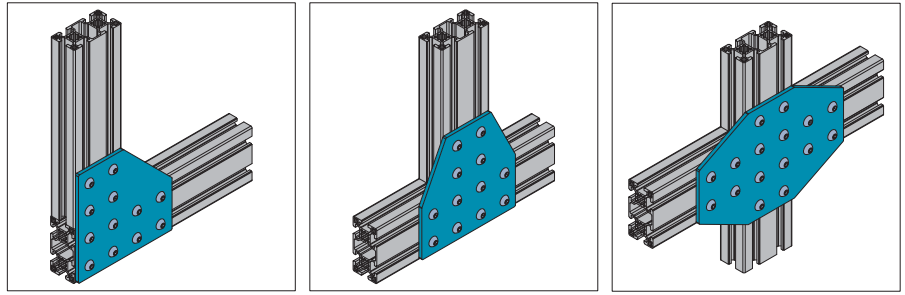





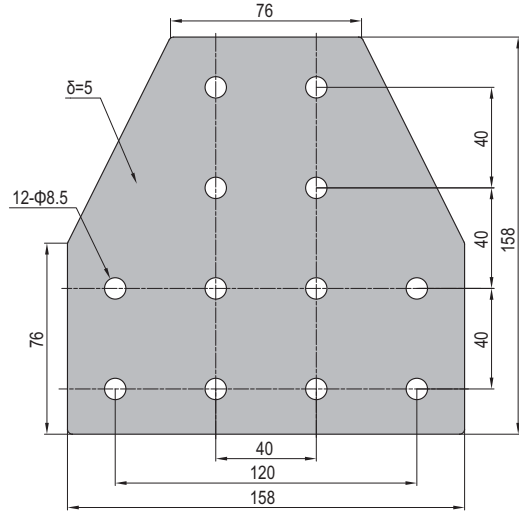
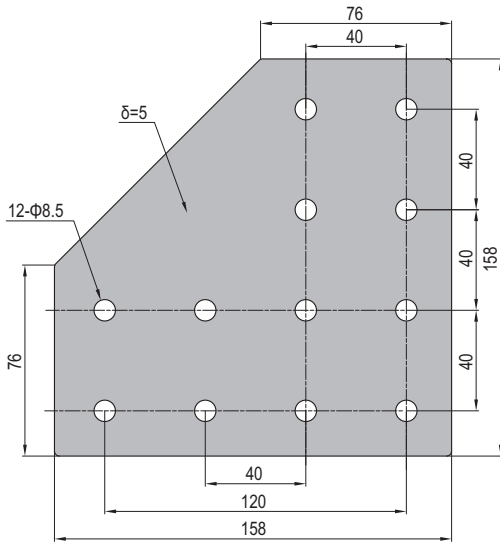

PG40-8080-01
40系列-8080-01

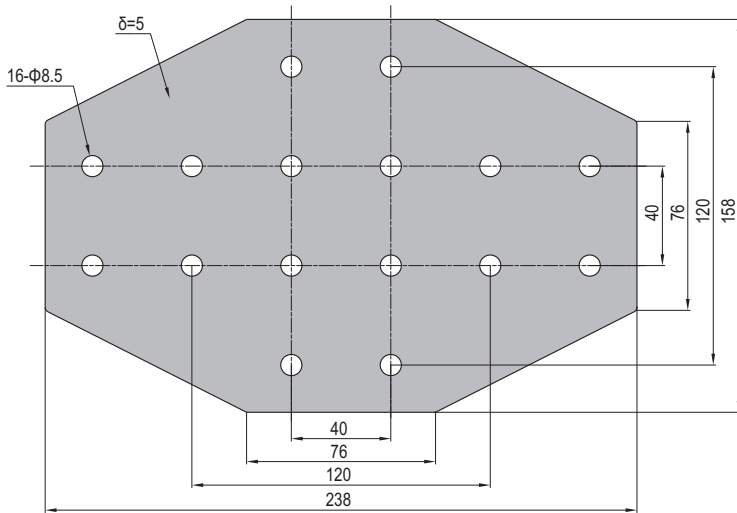
PG40-8080-02
40系列-8080-02



PG40-8080-03
40系列-8080-03



I	Fastening Set	O	Fastening Set
	M8x16 Bolt zinc plated		M8x16 Bolt zinc plated
	M8 Washer zinc plated		M8 Washer zinc plated
	M8 Nut nickel plated		M8 Pre-set Nut nickel plated

Description 产品描述	Fastening Set 紧固组件	Mass 重量 (g)	Part No. 订购编号
PG40-8080-01 (pcs) 40系列-8080-01 (单个供货)		656	3.53.40.8080.01
PG40-8080-01 (set I) 40系列-8080-01 (成套供货I)	12xI	879	3.53.40.8080.01.STI
PG40-8080-01 (set O) 40系列-8080-01 (成套供货O)	12xO	987	3.53.40.8080.01.STO
PG40-8080-02 (pcs) 40系列-8080-02 (单个供货)		656	3.53.40.8080.02
PG40-8080-02 (set I) 40系列-8080-02 (成套供货I)	12xI	879	3.53.40.8080.02.STI
PG40-8080-02 (set O) 40系列-8080-02 (成套供货O)	12xO	987	3.53.40.8080.02.STO
PG40-8080-03 (pcs) 40系列-8080-03 (单个供货)		945	3.53.40.8080.03
PG40-8080-03 (set I) 40系列-8080-03 (成套供货I)	16xI	1242	3.53.40.8080.03.STI
PG40-8080-03 (set O) 40系列-8080-03 (成套供货O)	16xO	1386	3.53.40.8080.03.STO