

Floor Elements
 地面组件

Leveling Foot-Pivot Foot
 支脚-尼龙微调

To support structure where gradual height adjustment is needed, the pivot foot has a small swiveling angle to fit slightly uneven floor. The connection between the pivot base and the spindle can be released with a tool.

尼龙微调支脚用来支撑高度需要微调的框架结构, 调节角度较小, 适用于相对较平整的地面, 此支脚的牙杆和底盘可用工具拆分。

Material and Color: Base-black PA6 Spindle-zinc plated steel Pad-black rubber
 材质: 底盘-增强尼龙6 牙杆-碳钢镀锌 胶垫-橡胶 颜色: 底盘-黑色 胶垫-黑色

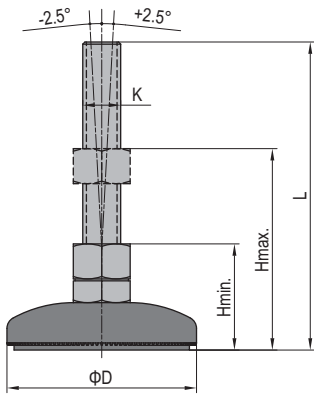
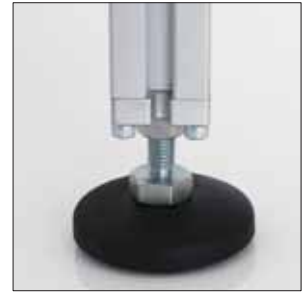
Pivot Foot
 尼龙微调支脚

Description 产品描述	D (mm)	KxL (mm)	H min. (mm)	H max. (mm)	Max. Static Load 最大静态载荷 (N)	Mass 重量 (g)	Part No. 订购编号
Pivot Foot-PA 6 Base 尼龙微调支脚 -增强尼龙6底盘	59	M12x90	45	70	4500	152	5.21.60.12.90
		M14x130		100	7000	220	5.21.60.14.130 <i>New!</i>
	79	M12x90	45	70	9000	188	5.21.80.12.90
		M12x130		100		218	5.21.80.12.130
		M16x130		100		328	5.21.80.16.130
	99	M12x130	45	100	10000	326	5.21.100.12.130
M16x130		100		436		5.21.100.16.130	

Leveling Foot-Swivel Foot
 支脚-球头

To support structure where gradual height adjustment is needed, the swivel foot has a ball joint between the base and spindle, thus allowing the foot to swivel to an angle up to 30°. It is suitable to be used on the components moved frequently.

球头支脚用来支撑需要调整高度的框架结构, 底盘和牙杆间有球头连接, 因此牙杆旋转角度可达30度, 适用于需要频繁移动的组件。

Material and Color: Base-black PA6 Spindle-zinc plated steel Pad-black rubber
 材质: 底盘-增强尼龙6 牙杆-碳钢镀锌 胶垫-橡胶 颜色: 底盘-黑色 胶垫-黑色

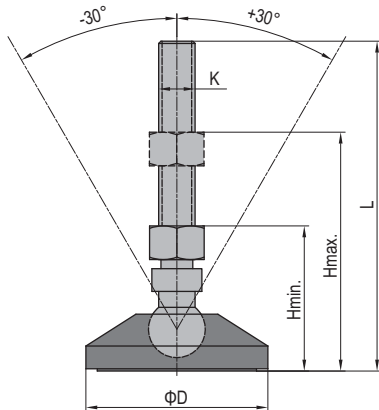
Swivel Foot
 球头支脚

Description 产品描述	D (mm)	KxL (mm)	H min. (mm)	H max. (mm)	Max. Static Load 最大静态载荷 (N)	Mass 重量 (g)	Part No. 订购编号
Swivel Foot-PA 6 Base 球头支脚 -增强尼龙6底盘	59	M12x90	45	70	4500	162	5.22.60.12.90
		M12x90		70	9000	198	5.22.80.12.90
	79	M12x130	45	100		9000	228
		M16x130		100	338		5.22.80.16.130
	99	M12x130	45	100	10000	336	5.22.100.12.130
		M16x130		100		446	5.22.100.16.130